

**CITY OF KENOSHA
PUBLIC WORKS DEPARTMENT- STREETS DIVISION
CARBIDE PLOW CUTTING EDGES, COVER BLADES AND CURB GUARDS
PROPOSAL NO. 18-18**

INSTRUCTIONS TO BIDDERS

Sealed bids will be accepted by the City of Kenosha, in the Department of Finance, Municipal Office Building, 625 52nd Street, Room 208, Kenosha, Wisconsin until:

Tuesday, December 18, 2018 at 2:30 P.M.

for providing and delivering subject equipment, all in accordance with City of Kenosha included specifications.

Vendors must furnish complete Manufacturer's Specifications and brochures describing in detail the equipment being proposed. Vendors shall answer all questions on the minimum specification worksheets and bid sheet. Any questions regarding specifications should be directed to Jay Getka, Fleet Maintenance Superintendent at (262) 653-4079.

All shipments from the awarded bidder shall be F.O.B. destination, prepaid and allowed to the City of Kenosha, Streets Division, 6415 - 35th Avenue, Kenosha, Wisconsin 53142 with no charges for packing or for cartage.

The City of Kenosha is exempt from Federal Excise Tax and State Sales Tax, therefore, costs should be made exclusive of these taxes. A Tax Exemption Certificate will be furnished to the successful vendor.

Bids must be sealed, forms fully completed, signed and dated, and submitted and returned clearly marked with the notice number and deadline date. Submittals received after the date and time of the opening will not be considered. No electronically communicated bids will be accepted.

The City reserves the right to accept or reject any or all submittals or to accept the submittal from the lowest responsive and responsible respondent.

Award will be made within 30 days of the bid opening. Respondent's shall state the anticipated delivery date on the bid form or the number of days from receipt of a purchase order.

Vendors shall propose and/or supply only products meeting Federal, State, and Industry Safety Standards.

Quantities may be increased or decreased to remain within budgetary constraints.

CITY OF KENOSHA
PUBLIC WORKS DEPARTMENT- STREETS DIVISION
CARBIDE PLOW CUTTING EDGES, COVER BLADES AND CURB GUARDS
PROPOSAL NO. 18-18

Specification
Compliance

MINIMUM SPECIFICATIONS

1 **GENERAL:** It is the intent of this specification to describe the minimum requirements for carbide cutting edges, cover blades and curb guards, to be purchased by the City of Kenosha for its snowplowing efforts.

2 **MANUFACTURER'S WARRANTY:** THE SUCCESSFUL VENDOR SHALL BE REQUIRED TO FURNISH A WRITTEN WARRANTY BY THE MANUFACTURER TO REPLACE ANY CUTTING EDGE THAT FAILS DURING IT'S LIFETIME DUE TO BREAKAGE OR PREMATURE FAILURE (i.e. CARBIDE INSERT BOND FAILURE). THIS WARRANTY SHALL APPLY TO BLADES AND EDGES EXPOSED TO ALL ROAD HAZARDS SUCH AS MANHOLES AND RAILROAD TRACKS. THE WARRANTY SHALL PROVIDE A MINIMUM OF A PRO-RATED CREDIT TO REPLACE ANY FAILED BLADE. SPECIFY IF DIFFERENT.

2.1 A copy of the warranty policy outlining the terms and conditions shall be included with the submittal. Specify if different.

3 **DESCRIPTION OF EQUIPMENT:** Submittals shall be considered only if the Vendor clearly shows without a doubt that the proposed cutting edges and cover blades are tried, proven, and in current use. A list of three (3) or more users shall be furnished with the submittal. Printed literature and detailed drawings from the manufacturer describing the items shall be included with the submittal. Specify if different.

4 **CARBIDE CUTTING EDGE REQUIREMENTS:** The following specifications describe the minimum requirements for all tungsten carbide cutting edges and cover blades:

4.1 Blades: The blades on the tungsten carbide cutting edges shall be flat hot-rolled finished steel which meets or exceed specifications for A36 or 1020 type steels. Specify if different.

4.2 The cover blades shall be constructed of high carbon steel with a Rockwell hardness on the "C" scale of 25-32 or Brinell hardness of 250-325. Specify hardness.

- 4.3 The plow blades shall have 11/16" diameter ROUND holes to receive 5/8" diameter bolts. COUNTERSINKING IS NOT ACCEPTABLE. Location and spacing of the holes shall be as specified in the drawings supplementing the specifications. Specify compliance. _____
- 4.4 The groove for the carbide inserts shall be milled in the center of the blade edge. Specify if different. _____
- 4.5 The center of the holes shall be in line within 1/32" of established center line. Specify if different. _____
- 4.6 The tolerances for hole spacings shall be + / - 1/16", non-accumulative from center to center, across full length of blade. Specify if different. _____
- 4.7 The finished blade section shall be free of warpage and longitudinal deviation not to exceed 1/8" in a four foot section. Specify if different. _____
- 4.8 Each blade section shall be marked in paint with the manufacturer's identification stamp. Specify if different. _____
- 4.9 The finished blade sections shall be given one coat of rust resistant paint. Specify if different. _____
- 4.10 The finished blade sections shall have clear paint markings showing the front edge of the blade to avoid improper mounting. Specify if different. _____
- 5 **TUNGSTEN CARBIDE INSERTS:** The inserts shall be a high shock WC grade of tungsten carbide with eleven to twelve and one-half percent (11 to 12-1/2 %) cobalt content. Specify cobalt content. _____
- 5.1 Density: 14.1 minimum to 14.6 maximum. Specify density. _____
- 5.2 Hardness: 87.5 minimum to 89.0 maximum Rc. "A" scale. Specify hardness rating. _____
- 5.3 Transverse Rupture Strength: 350,000 p.s.i. minimum. Specify strength in p.s.i. _____

- 5.4 Porosity: Based on testing in accordance with ASTM designation B276-79. A06 B00 C00 Specify porosity. _____
- 5.5 The tungsten carbide shall be of North American origin. Specify compliance. _____
- 5.6 The inserts shall be a trapezoid design of the following dimensions:
 - 5.6.1 Height: .635" +/- .005 (long side). Specify height. _____
 - 5.6.2 Width: .365 +/- .010". Specify width. _____
 - 5.6.3 Length: 1" nominal. Specify length. _____
 - 5.6.4 Bottom Angle: 25 degrees +/- one degree with a nose radius of 1/16" minimum. Specify bottom angle. _____
- 5.7 A metallurgical evaluation of the carbide insert shall show no evidence of cross grade contamination. Evaluation shall be based on a photomicrograph of a polished and etched specimen at 500X magnification. Specify if different. _____
- 6 **BRAZING:** The brazing material shall be a high strength alloy type. The shear strength of the braze material shall be rated by the manufacturer at 30,000 p.s.i. minimum. Specify shear strength. _____
- 6.1 The tungsten carbide inserts shall be positioned in line within the milled groove of the cutting edge section. Carbide insert spacing shall be no more than .010 inches between inserts. Specify if different. _____
- 6.2 The inserts shall be brazed continuously on all sides consistent with sound brazing practice with no evidence of voids or use of shims. Specify if different. _____
- 6.3 Each blade section shall contain one (1) insert, one inch (1") nominal length for each inch of blade section length. Specify if different. _____
- 6.4 The difference between the highest and lowest tip point on any two adjacent inserts shall not exceed 1/32" on any given blade assembly. Specify if different. _____

- 7 **CARBIDE CURB GUARDS:** The dimensions and hole spacings of the carbide curb guards shall be as specified in the drawings enclosed in this specification.
- 7.1 The carbide curb guards shall be constructed from high impact, low carbon (.30 maximum) AR type material. Specify if different.
-
- 7.2 The carbide curb guards shall have a 1/4" X 1 1/4" high impact, carbon steel bar running the full length of the front weld cutting edge. The impact bar shall be welded to the top front surface of the guard with a 1/4" continuous fillet weld. Specify if different.
-
- 7.3 The carbide curb guards shall have **11/16" diameter round holes**, without countersinking, to receive 5/8" diameter bolts. **COUNTERSINKING IS NOT ACCEPTABLE.** Specify compliance.
-
- 7.4 Each carbide curb guard shall be given one coat of rust resistant paint. Specify if different.
-
- 7.5 The carbide curb guards shall have a cutting edge and radius hard-surface weld meeting the following minimum percent chemical analysis: Carbon 2.5 weld center, 4.0 weld cap; silicon 1.5 weld center, 0.5 weld cap; chrome 11.00 weld center, 24.00 weld cap; high temperature carbide formers 0.5 weld center, 0.5 weld cap; nitride formers 0.5 weld center, 0.5 weld cap; Fe balance weld center, balance weld cap; Rc hardness 50 minimum weld center, 55 minimum weld cap. Specify any deviations from these specifications.
-
- 7.6 The weld height on the carbide curb guard cutting edges shall be 7/8" minimum from the guard base steel plate to the top of the weld. The weld deposit profile shall be parallel and flush (+/- 1/32") to the blade side of the curb guards. The weld overlay shall be completely fused to the front impact bar. Specify if different.
-
- 7.7 The radius of the carbide curb guards (right side only) shall have a minimum of eleven (11) square inches of hard surface weld 3/16" in thickness. Specify if different.
-
- 7.8 The carbide curb guard wear edges shall form vertical cross checks at the rate of one (1) check minimum per inch of
-

longitudinal hard surface weld. Specify if different.

7.9 The carbide curb guards shall not have any longitudinal cracks at the fusion zone where hardface weld meets the base steel. **WELD REPAIRS IN THIS AREA ARE NOT ACCEPTABLE.** Specify if compliance.

7.10 The carbide curb guard cutting edges shall have a 1/2" hard surface weld bead along the front edge to allow the cutting edge to conform to the correct blade wear angle. Specify if different.

7.11 The carbide curb guards shall be labeled with the manufacturer's name and address. The guards shall also be labeled with "Use Grade 8 Bolts and Nuts – Torque to 220 ft/lbs." Specify if different.

7.12 The successful vendor shall provide a curb guard sample to the Kenosha Street Division for approval before the balance of the curb guard order is manufactured, if requested. Specify if different.

8 **CURB GUARD EXTENSIONS:** The dimensions of the curb guard extensions shall be as specified in the drawings supplementing these specifications.

8.1 The curb guard extensions shall be constructed from high impact, low carbon A36 steel. Specify if different.

8.2 The curb guard extensions do not require mounting holes as they will be welded by the City to the top of City-owned curb guards. Specify if different.

8.3 The curb guard extensions shall be given one coat of black primer. Specify if different.

8.4 The curb guard extensions shall have a straight bottom edge and the same radius as City-owned curb guards to facilitate welding. Specify if different.

8.5 The successful vendor shall provide a curb guard extension sample to the Kenosha Street Division for approval before the balance of the order is manufactured, if requested. Specify if

different.

9 **ALTERNATE APPROVALS:** Alternate approvals may be considered if samples and detailed drawings are provided with submittal.

10 **QUANTITIES:** The City intends to purchase the following quantities of cutting edges, cover blades and curb guards. The City reserves the right to modify the actual purchase quantities to stay within budgetary limits.

10.1 Wausau MF-5 carbide cutting edge: Forty (40) sets or 160 pieces. Specify price per piece. _____

10.2 Wausau MF-5 cutting edge cover blade: Forty (40) sets or 160 pieces. Specify price per piece. _____

10.3 Right Side Curb Guard with bottom impact bar and carbide weld on radius. 120 pieces. Specify price per piece. _____

10.4 Curb Guard four (4) inch extensions: 150 pieces. Specify price per piece. _____

10.5 Wausau PW-9 patrol wing carbide cutting edge. 22 sets or 44 pieces. Specify price per piece.

10.6 Monroe patrol wing carbide cutting edge. Five (5) sets of ten (10) pieces. Specify price per piece.

10.7 Monroe patrol wing cover blades: Five (5) sets or ten (10) pieces. Specify price per piece.

**CITY OF KENOSHA
PUBLIC WORKS DEPARTMENT- STREETS DIVISION
CARBIDE PLOW CUTTING EDGES, COVER BLADES AND CURB GUARDS
PROPOSAL NO. 18-18**

BID

| QTY | UNIT | EQUIPMENT DESCRIPTION | UNIT COST | EXTENDED COST |
|-----|------|--|-----------|---------------|
| 160 | PC | WAUSAU MF-5 CARBIDE CUTTING EDGE (10.1) | \$ | \$ |
| | | BRAND / PART #: _____ | | |
| 160 | PC | WAUSAU MF-5 CUTTING EDGE COVER BLADE (10.2) | \$ | \$ |
| | | BRAND / PART #: _____ | | |
| 120 | PC | RIGHT CURB GUARD W/ RADIUS CARBIDE WELD (10.3) | \$ | \$ |
| | | BRAND / PART #: _____ | | |
| 150 | PC | CURB GUARD- FOUR (4) INCH EXTENSIONS (10.4) | \$ | \$ |
| | | BRAND / PART #: _____ | | |
| 44 | PC | WAUSAU PW-9 WING CARBIDE CUTTING EDGE (10.5) | \$ | \$ |
| | | BRAND / PART #: _____ | | |
| 10 | PC | MONROE PATROL WING CARBIDE CUTTING EDGE (10.6) | \$ | \$ |
| | | BRAND / PART #: _____ | | |
| 10 | PC | MONROE PATROL WING COVER BLADE (10.7) | \$ | \$ |
| | | BRAND / PART #: _____ | | |
| | | | | |
| | | TOTAL COST: | | \$ |

Delivery shall be made within _____ days or _____ days of receipt of Purchase Order.

Submitted By:

Firm Name: _____

Signature: _____

Print Name: _____

Firm Address: _____

Firm Phone No.: _____ Firm FAX: _____

E-mail: _____

Date: _____

PAYMENT TERMS: _____% _____, NET _____ DAYS

BLADE AND CURB GUARD DIMENSIONS: The following diagrams are to be used as a guide by the vendor. The vendor shall be responsible for verifying bolt spacings and dimensions with the plow manufacturer.

Wausau MF-5 Carbide Cutting Edge:

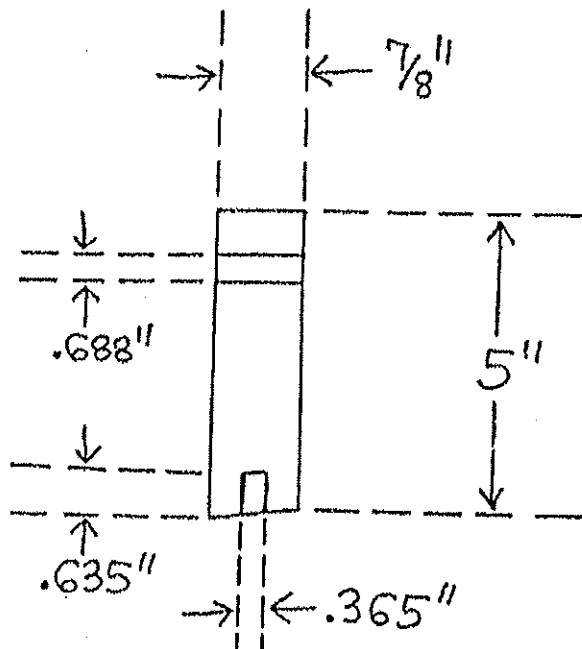
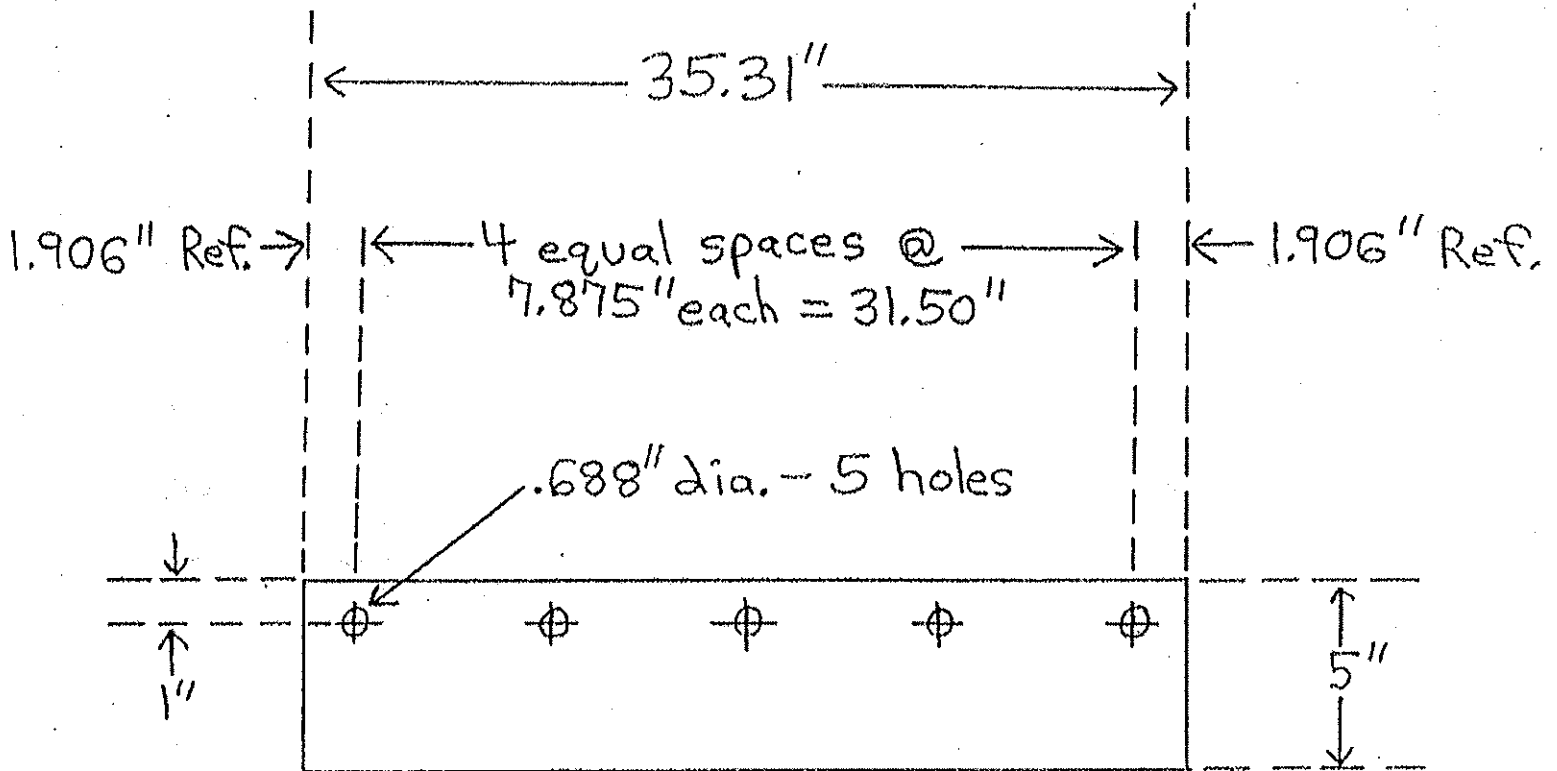

Wausau MF-5 Cutting Edge Cover Blade:

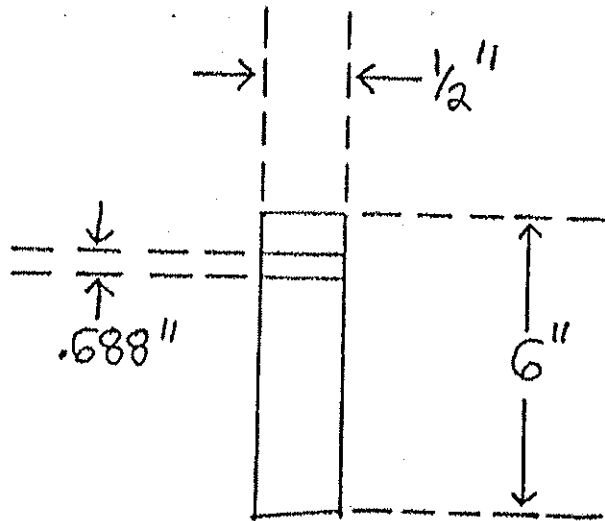
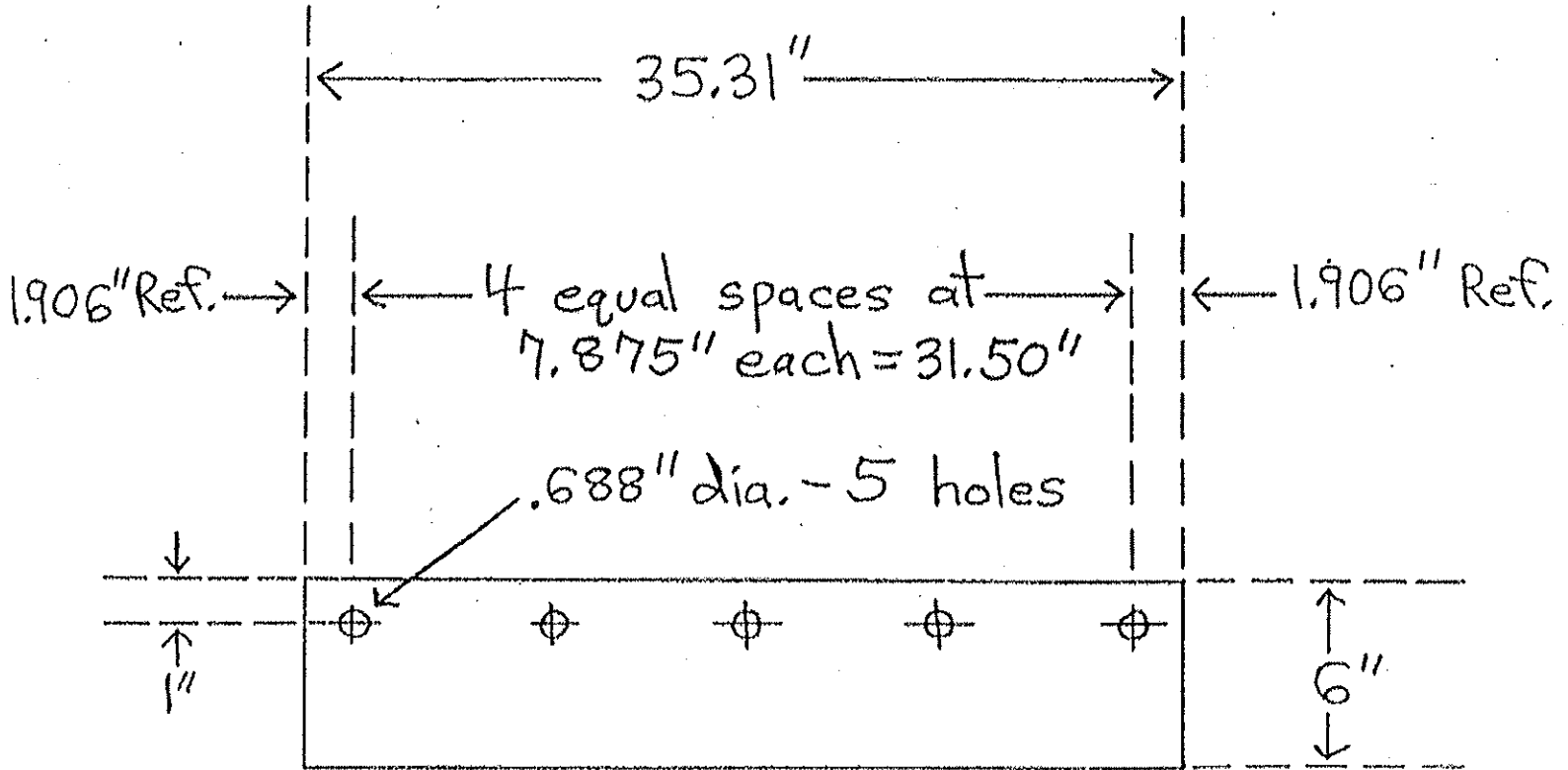

4" Curb Guard Extension (5/8" thick)

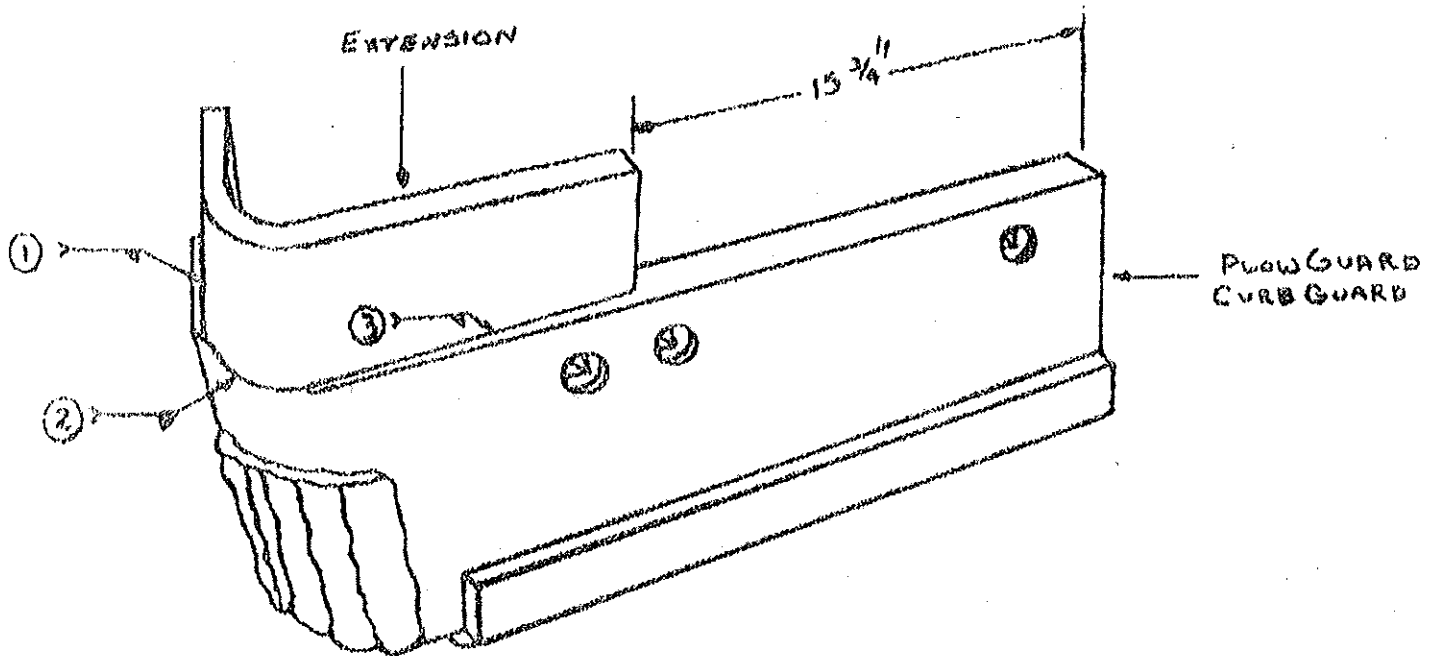

All Welds = $\frac{1}{4}$ " x 3"

Weld Locations:

1. Side edge (Outside)
2. Corner edge (Inside)
3. Front edge (Outside)

Part cut length = $13'' \pm 1/16''$

STANDARD CURB GUARD WITH CARBIDE WELD

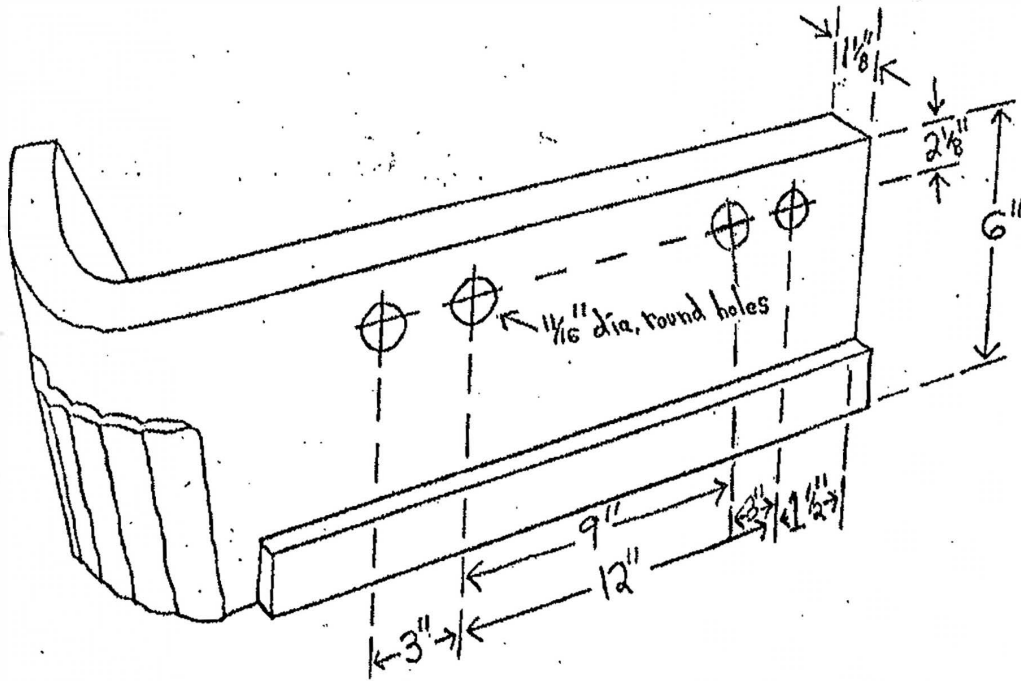
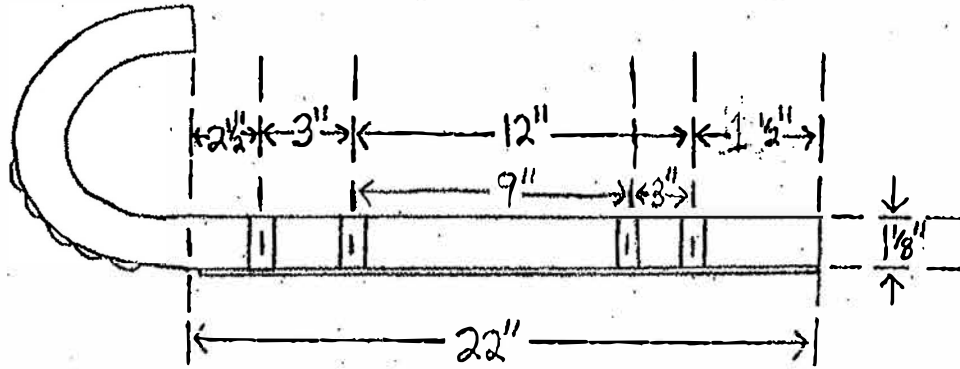

BLADE AND CURB GUARD DIMENSIONS: The following diagrams are to be used as a guide by the vendor. The vendor shall be responsible for verifying bolt spacings and dimensions with the plow manufacturer.

A. Schmidt Wausau PW-9 Patrol Wing Carbide Cutting Edge:

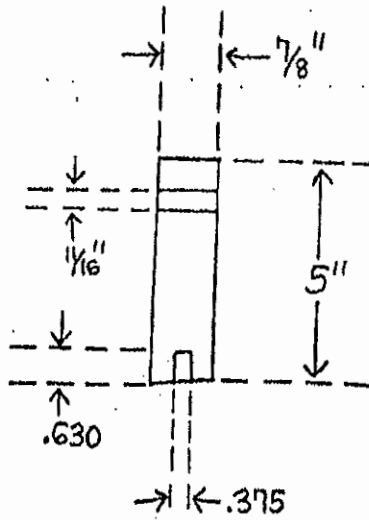
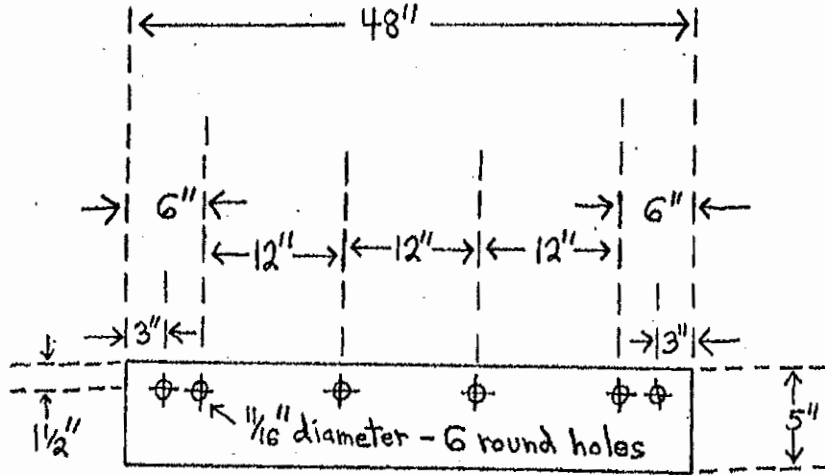

Schmidt Wausau PW-9 Patrol Wing Cutting Edge Cover Blade

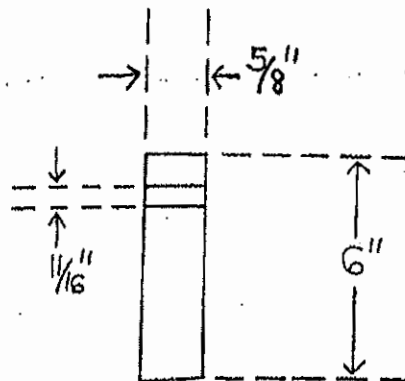
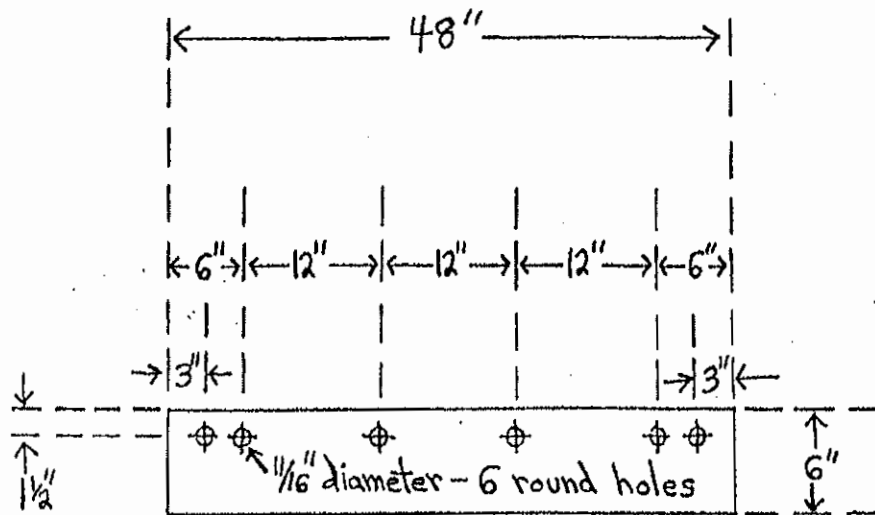

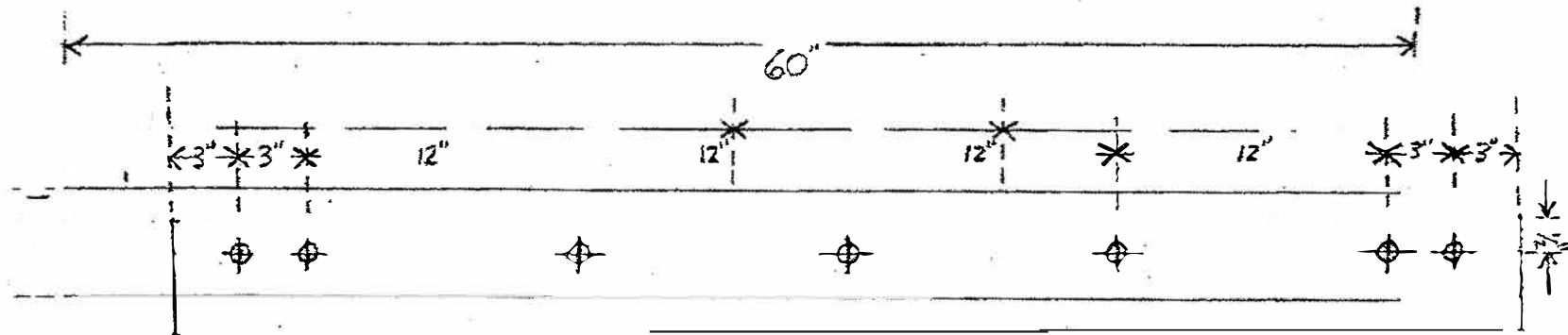

Scale: 1" = 6"

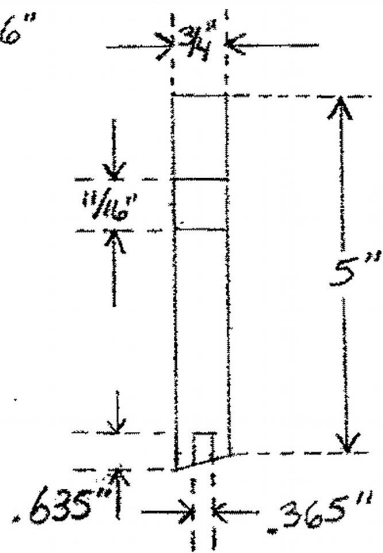

Scale: 1" = 2"

**MONROE PATROL WING
CARBIDE CUTTING EDGE**

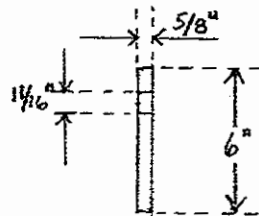
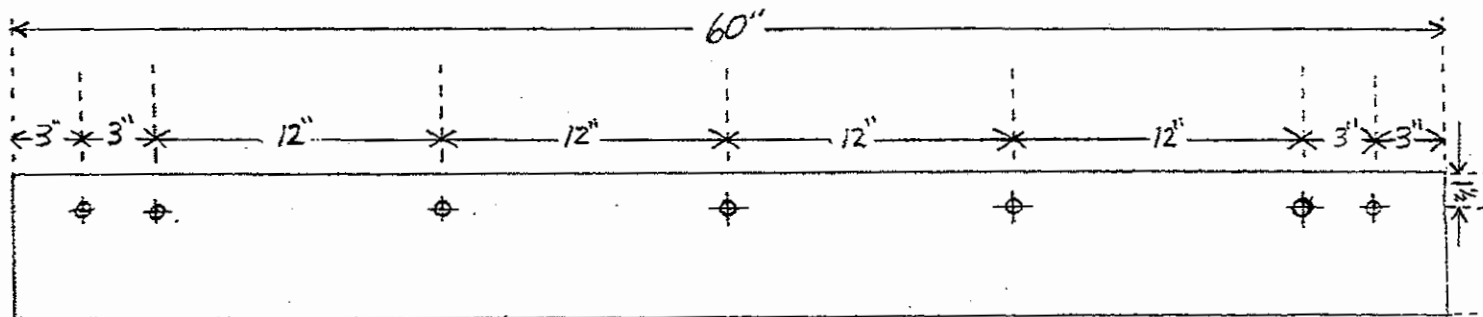

**MONROE PATROL WING
CUTTING EDGE
COVER BLADE**

Scale: 1" = 6"

**CITY OF KENOSHA
PUBLIC WORKS DEPARTMENT- STREETS DIVISION
CARBIDE PLOW CUTTING EDGES, COVER BLADES
AND CURB GUARDS PROPOSAL NO. 18-18**

REFERENCES

Provide names, addresses and phone numbers of not less than three (3) relevant references of equipment users.

(1) _____

(2) _____

(3) _____

(4) _____

(5) _____

(6) _____

